

The Importance of Fire Sealing Service Penetrations

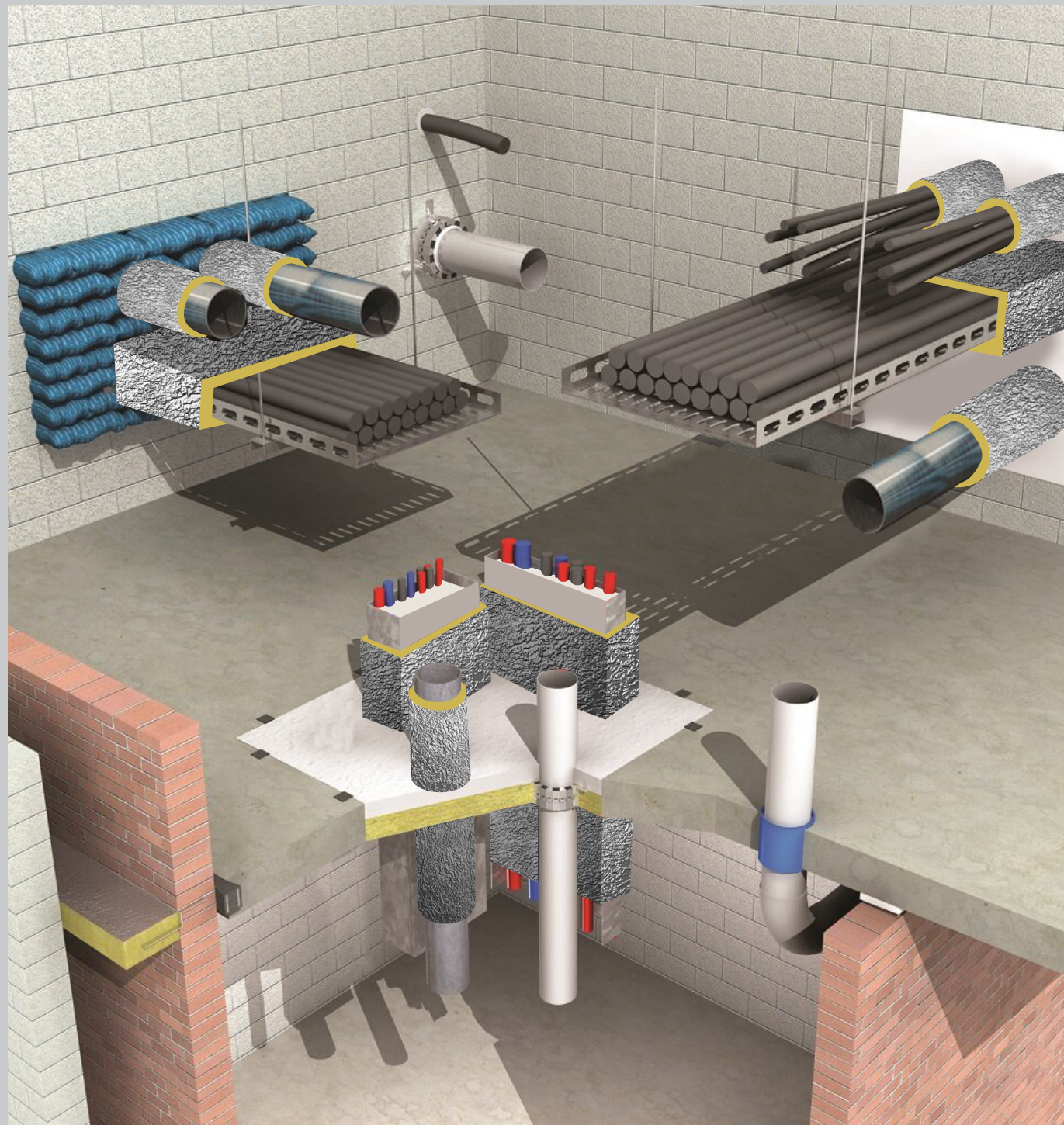

What are fire seals?

Fire seals are used to protect openings in fire-resisting components of buildings and are extremely important in restricting the spread of fire throughout the property. Fire seals are best defined as systems installed to openings that prevent fire, smoke and heat from passing through the building. Their main goal is to protect building occupants and can also be used to protect the structure of the property, preserve its infrastructure and safeguard adjacent properties.



The Importance of fire seals

Fire seals are a vital component in a building's fire protection strategy.

Bowers specialises in the fire sealing of services which penetrate fire rated elements. These include hydraulic and electrical services. Risk occurs when these services pass through the fire rated elements without adequate fire protection, potentially exposing the building to the spread of fire between fire compartments.

A range of systems have been developed by specialist manufacturers to seal such service

penetrations. These systems are independently tested and certified for specific uses and site conditions.

Building compliance and certification is only valid when the choice of passive fire sealing system matches the tested prototype.

Bowers' management, supervisors and trades personnel are experienced in the installation of passive fire protection to meet building design and BCA requirements.

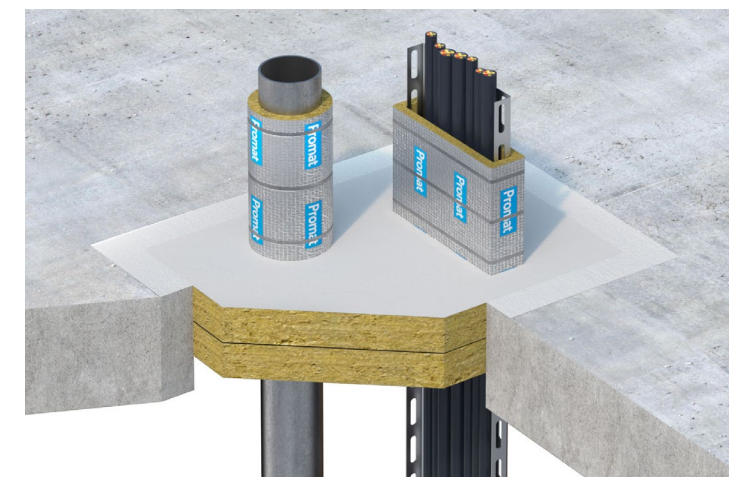
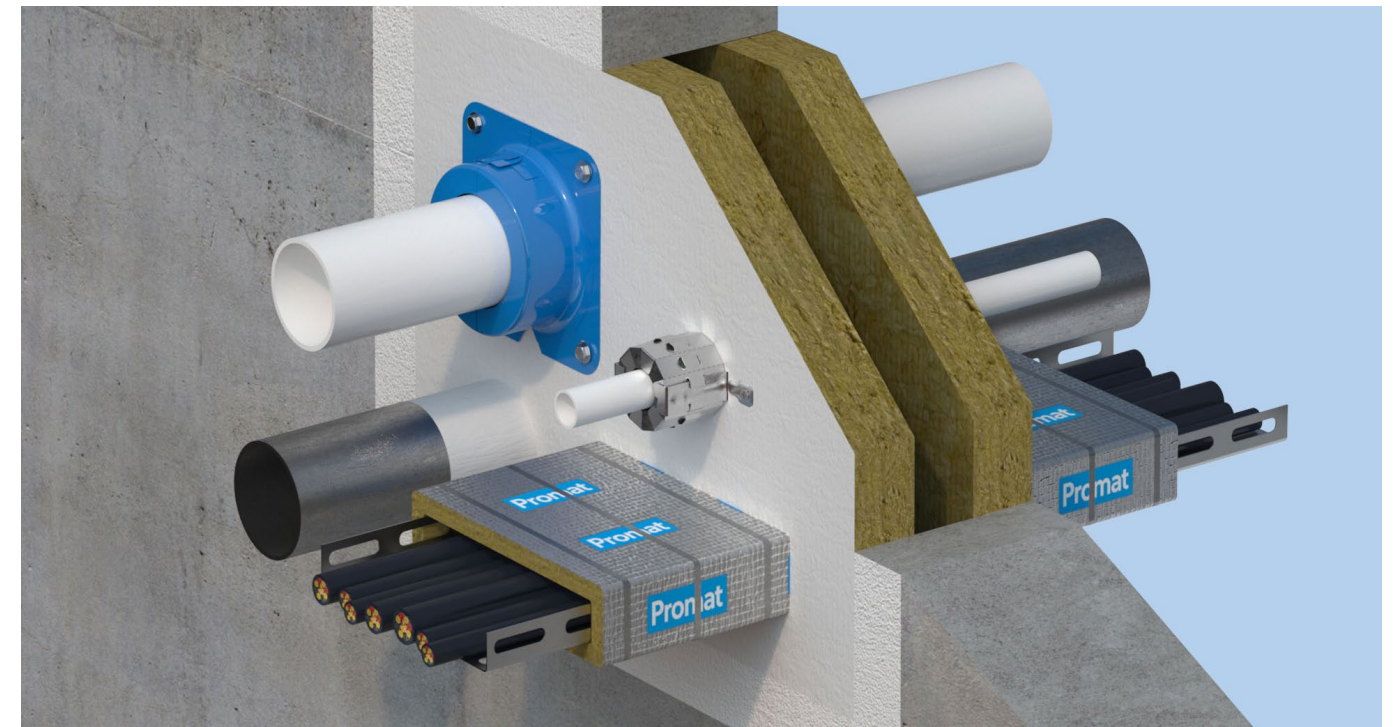



FIRE SEALING INSTALLATION



FIRE SEALING INSTALLATION

Why use Bowers?

- Bowers has been working as a passive fire rating contractor for over 50 years and specifically assessing fire seals since the 1990s. Our experienced teams of auditors and technicians can complete all annual maintenance inspections and repairs to ensure your fire seals are fully compliant.
- We can complete any repairs necessary, including repairs or replacement of fire seals, rectification of penetrations in fire barriers, and installation of suitable maintenance access.
- Upon completion of our repairs, Bowers will provide certification of all works.

- Bowers is accredited with the Fire Protection Association Accreditation Scheme (FPAS) and the Queensland Building and Construction Commission (QBCC) and is an accredited applicator of a range of approved products to the relevant Australian Standards.
- Bowers is independently risk accredited by Greencap Cm3.

BOWERS IS AN ACCREDITED APPLICATOR FOR A RANGE OF FIRE RATED PRODUCTS USED IN THE INDUSTRY.

Bowers' Services

Bowers' offers comprehensive services and delivery of Passive Fire Protection including Fire Sealing Service Penetrations across various sectors.

Its offering includes:

- Audits
- Compliance Reports
- Rectification of existing passive fire protection systems
- Installation of new passive fire protection systems
- Certification of installed systems
- Technical advice

WE ARE ACCREDITED WITH THE FOLLOWING ORGANISATIONS





RYDGES ESPLANADE RESORT CAIRNS



Case Study: Rydges Esplanade Resort Cairns fire seal repairs

SECTOR:

Building / Hotels

CLIENT:

Rydges Esplanade Resort Cairns

PROJECT COMPLETION:

December 2020

VALUE:

\$0.2M+

ADDRESS:

209-217 Abbott Street, Cairns

PROJECT OVERVIEW:

Rydges Esplanade Resort with both its guest rooms and serviced apartments is a tourism and accommodation mecca in the heart of Cairns that overlooks the Coral Sea. Bowers were engaged to repair fire seal defects – providing all labour and materials required.

SERVICES OFFERED:

Bowers completed fire sealing to service penetrations throughout the entire resort ensuring compliance with all WHS requirements, including COVID-19 safe practices. Bowers provided certification and a photographic report of all completed work including over 1,200 separate items.

Being one of Cairns' leading resorts, Bowers were required to complete the work with minimal disruption to the resort's daily operations. Additionally, Bowers carefully managed the logistics of getting materials and labour from the Gold Coasts to Cairns.

The client was extremely happy with the outcome and the standard of fire safety works completed by Bowers. Bowers worked closely with the client adopting strong and constant communication to ensure works did not impede with the resorts' daily activities. Bowers' understanding of working within a live operational resort while maintaining 100% safety of all guests, staff and the neighbouring community was paramount to the project's success.



South-East Queensland
Unit 4, 18 Blanck Street
Ormeau Qld 4208

T 07 3266 2366

E scallinan@bowsers.com.au

W bowsers.com.au